

NOVA PRO SCALA

F8 inset panel for inset drawer H186, Crystal and Crystal Plus

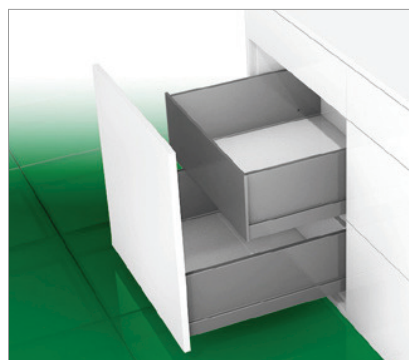

- Colour-coordinated aluminium front panel profile
- High-quality design with smooth inside and outside surfaces
- Same dimensions as for standard drawers (inside depth)
- Also for cutting to length (see page 48)

Packaging unit (PU):
207 = 10 items in a cardboard box

Note:
Front-bottom connector recommended from width 600 mm (refer to Accessories)

ORDER INFORMATION

1 F8 inset panel for inset drawer H186, Crystal and Crystal Plus, S16 and S18/S19 Set: Inset panel with pre-assembled installation hook, front clips and cover caps										
S16*		Stone			Ice			Silver		
KB	Art.-no.	PU		Art.-no.	PU		Art.-no.	PU		
250	F102104984	207		F102104999	207		F102105014	207		
300	F102104986	207		F102105001	207		F102105016	207		
350	F102104987	207		F102105002	207		F102105017	207		
400	F102104988	207		F102105003	207		F102105018	207		
450	F102104989	207		F102105004	207		F102105019	207		
500	F102104990	207		F102105005	207		F102105020	207		
600	F102104992	207		F102105007	207		F102105022	207		
800	F102104994	207		F102105009	207		F102105024	207		
900	F102104995	207		F102105010	207		F102105025	207		
1000	F102104996	207		F102105011	207		F102105026	207		
1200	F102104998	207		F102105013	207		F102105028	207		
S18/S19*		Stone			Ice			Silver		
KB	Art.-no.	PU		Art.-no.	PU		Art.-no.	PU		
250	F102105221	207		F102105236	207		F102105251	207		
300	F102105223	207		F102105238	207		F102105253	207		
350	F102105224	207		F102105239	207		F102105254	207		
400	F102105225	207		F102105240	207		F102105255	207		
450	F102105226	207		F102105241	207		F102105256	207		
500	F102105227	207		F102105242	207		F102105257	207		
600	F102105229	207		F102105244	207		F102105259	207		
800	F102105231	207		F102105246	207		F102105261	207		
900	F102105232	207		F102105247	207		F102105262	207		
1000	F102105233	207		F102105248	207		F102105263	207		
1200	F102105235	207		F102105250	207		F102105265	207		

* upon request

NOTES

- Inset panel S16 or S19 only in combination with full extension slide S16/S19 (see page 34 and 38)
- Inset panel S18 only in combination with full extension slide S18 (see page 36 and 40)

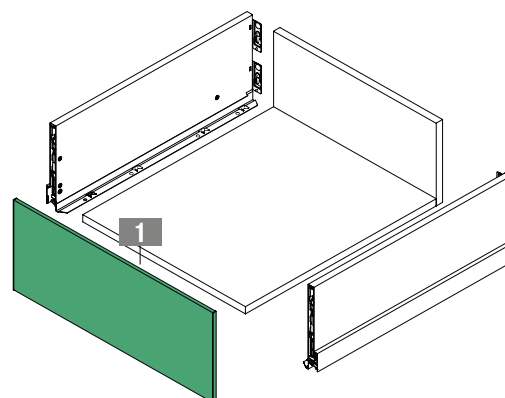

PAGE REFERENCES

Drawer sides	13	Steel back panels	58	Sensomatic	81
Slides	34	Designer panels	64	Organising systems	103
Individual components	48	Accessories	66	Assembly technology	116

PLANNING DIMENSIONS

All dimensions in millimetres

Installation dimensions	Front panel profile H186									
	<table border="1"> <thead> <tr> <th>Slide</th> <th colspan="2">Can be used with</th> </tr> </thead> <tbody> <tr> <td>S</td> <td>16/19</td> <td>18</td> </tr> <tr> <td>EB</td> <td>29</td> <td>30</td> </tr> </tbody> </table> <p>Note: Slide available in two versions: For S16/S19 and S18. Refer to the Slides section (from page 34).</p>	Slide	Can be used with		S	16/19	18	EB	29	30
Slide	Can be used with									
S	16/19	18								
EB	29	30								
<p>* Recommendation/Minimum dimension: 49.5 mm/Tipmatic Soft-close: 58 mm</p>										

Fixing positions for full extension slide

Euro screw Ø 6 x 13 mm

40 kg **70 kg**

LEGEND

BB	Bottom panel width	KV	Front edge of cabinet	RWB	Width of back panel
EB	Construction width	LWK	Inside cabinet width	S	Cabinet side wall
IBB	Inset panel width	MET	Minimum installation depth		
KB	Cabinet width	NL	Nominal length		